

Newdeal REGULATOR

Highly reliable, heavy-duty piston-operated regulator.

- Stability of the set pressure as the upstream pressure varies
- Standard overpressure blowoff valve
- Can be fixed to the wall using the holes in the sides of the body.

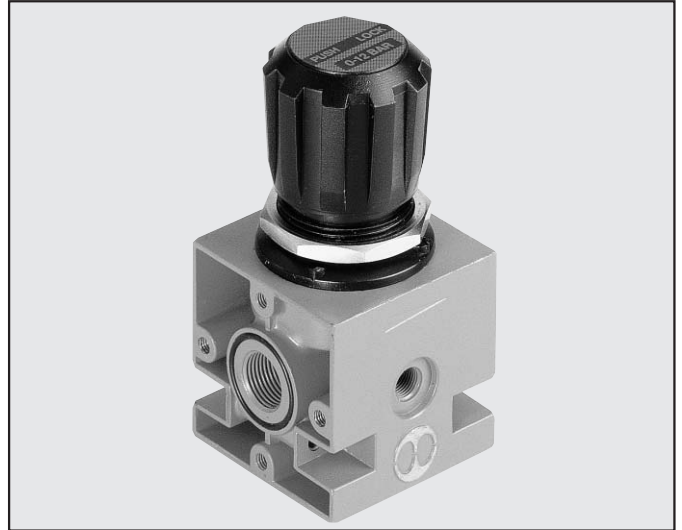

TECHNICAL DATA	REG. ND 1/4"	REG. ND 3/8"	REG. ND 1/2"	REG. ND 3/4"	REG. ND 1"
Threaded port	1/4"	3/8"	1/2"	3/4"	1"
Setting range	0 to 2 - 0 to 4 - 0 to 8 - 0 to 12				
Max. inlet pressure	1.8				
	18				
	261				
Flow rate at 6.3 bar (0.63 MPa-91 psi)	NI/min	200	1100	2500	
ΔP 0.5 bar (0.05 MPa - 7 psi)	scfm	7	39	89	
Flow rate at 6.3 bar (0.63 MPa-91 psi)	NI/min	650	2500	4500	
ΔP 1 bar (0.1 MPa - 14 psi)	scfm	23	89	160	
Fluid	Filtered, lubricated or unlubricated compressed air. Lubrication, if used, must be continuous				
Max temperature at 1 MPa; 10 bar; 145 psi	°C	50°			
	°F	122°			
Weight	Kg	0.3	0.8	1.5	
Wall fixing screws		M4x40	M4x55	M6x75	
Mounting	In any position				
Gauge port	G 1/8"	G 1/8"	G 1/8"	1/4"	1/4"
Notes:	The regulator pressure must always be set upwards. For increased sensitivity, use a pressure regulator with a rated pressure as close as possible to the required value. Do not take off air from gauge ports.				

3

COMPONENTS

- ① Zamak body
- ② Technopolymer bell
- ③ Technopolymer knob
- ④ Technopolymer piston rod
- ⑤ Technopolymer plug
- ⑥ OT58 brass adjusting screw
- ⑦ OT58 brass nut
- ⑧ Technopolymer ring nut
- ⑨ OT brass rod
- ⑩ Valve with NBR vulcanized gasket
- ⑪ NBR lip seal
- ⑫ NBR relieving seal
- ⑬ Steel adjusting spring
- ⑭ Steel valve compression spring
- ⑮ NBR gaskets

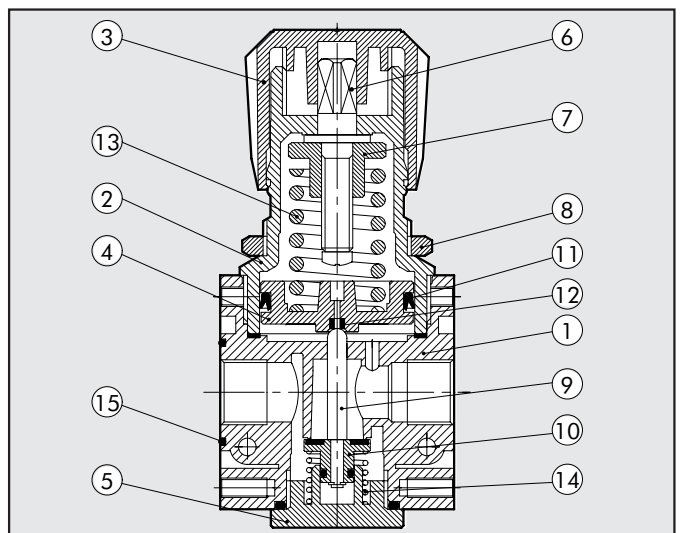

FLOW CHARTS

REG 1/4

$P_m = 0,7 \text{ MPa}$; 7 bar; 102 psi
Inlet pressure

psi MPa bar

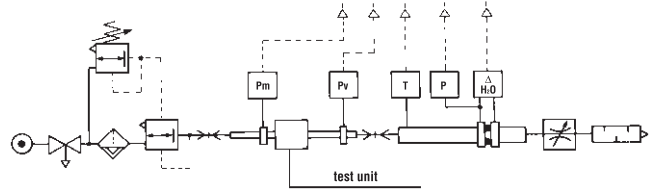
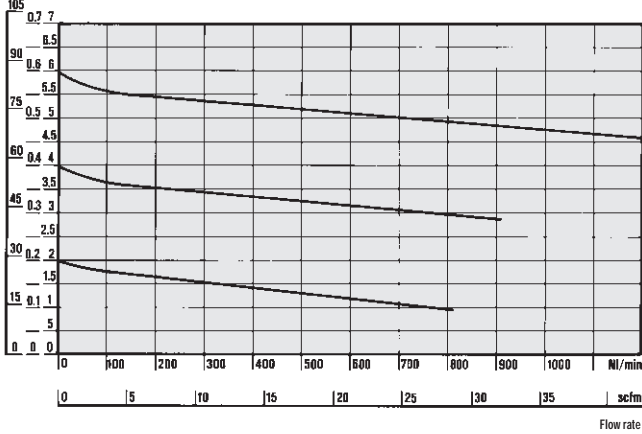

- Flow tests carried out at the Department of Mechanics, Turin Polytechnic, using the computerized test bench following CETOP RP50R recommendations (ISO DIS 6358-2-approved) with ISO 5167 diaphragm gauge.

REG 3/8 - 1/2

$P_m = 0,7 \text{ MPa}$; 7 bar; 102 psi
Inlet pressure

psi MPa bar

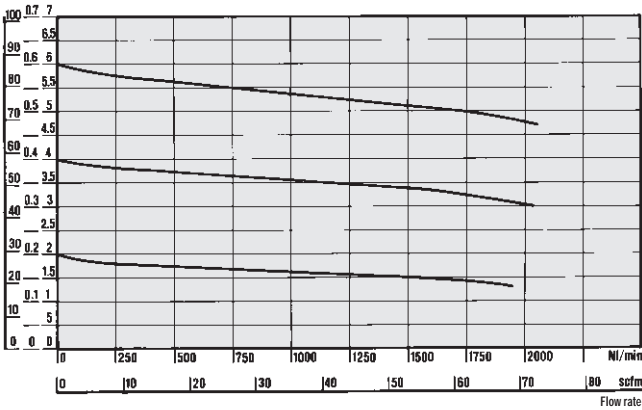

REG 3/4 - 1"

$P_m = 0,7 \text{ MPa}$; 7 bar; 102 psi
Inlet pressure

psi MPa bar

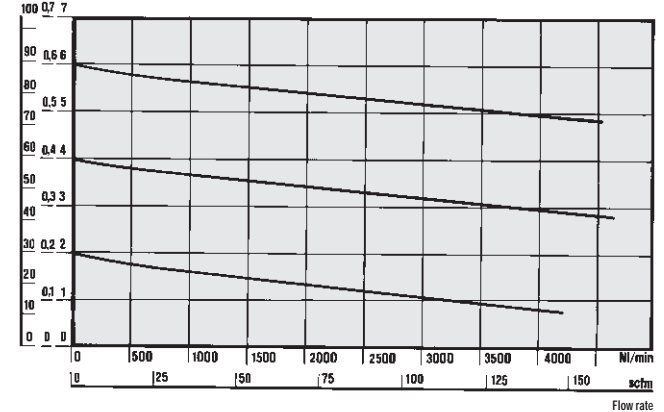

DIMENSIONS

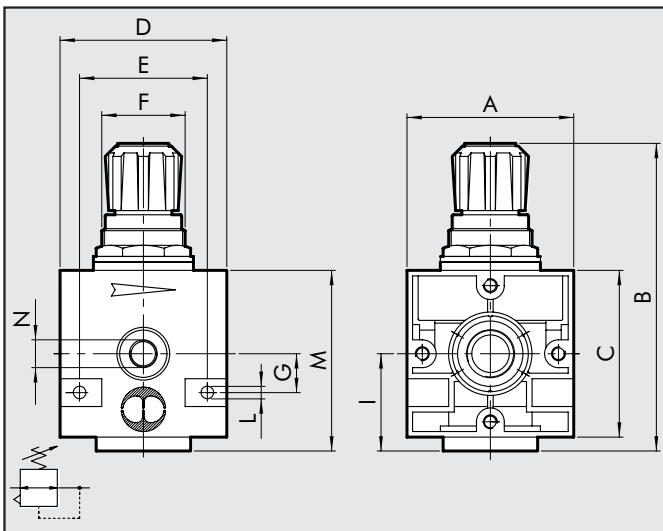

	G 1/4	G 3/8	G 1/2	G 3/4	G 1"
A	42	60	80		
B	94	130	184		
C	42	60	80		
D	42	60	80		
E	32	46	66		
F	30x1.5	38x2	55x2		
G	10	14	22		
I	25	35	47		
L	M4 hole	M4 hole	M6 hole		
M	49	70	94		
N	1/8	1/8	1/4		

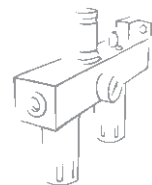

KEY TO CODES

REG	1/4	02
ELEMENT	THREADED PORT	SETTING RANGE
REG	1/4 3/8 1/2 3/4 1	02 04 08 012

ORDERING CODES

Code	Description
1202001	REG 1/4 04
1202002	REG 1/4 08
1202003	REG 1/4 012
1202004	REG 1/4 02
1302001	REG 3/8 04
1302002	REG 3/8 08
1302003	REG 3/8 012
1402001	REG 1/2 04
1402002	REG 1/2 08
1402003	REG 1/2 012
1502001	REG 3/4 04
1502002	REG 3/4 08
1502003	REG 3/4 012
1602001	REG 1 04
1602002	REG 1 08
1602003	REG 1 012

NOTES

Blank area for notes, consisting of 20 horizontal lines.

NOTES

Blank area for notes, consisting of 20 horizontal lines.